



## Notions of Position in Social Network Analysis

Stephen P. Borgatti, Martin G. Everett

*Sociological Methodology*, Volume 22 (1992), 1-35.

Stable URL:

<http://links.jstor.org/sici?sici=0081-1750%281992%2922%3C1%3ANOPISN%3E2.0.CO%3B2-0>

---

Your use of the JSTOR archive indicates your acceptance of JSTOR's Terms and Conditions of Use, available at <http://www.jstor.org/about/terms.html>. JSTOR's Terms and Conditions of Use provides, in part, that unless you have obtained prior permission, you may not download an entire issue of a journal or multiple copies of articles, and you may use content in the JSTOR archive only for your personal, non-commercial use.

Each copy of any part of a JSTOR transmission must contain the same copyright notice that appears on the screen or printed page of such transmission.

*Sociological Methodology* is published by American Sociological Association. Please contact the publisher for further permissions regarding the use of this work. Publisher contact information may be obtained at <http://www.jstor.org/journals/asa.html>.

---

*Sociological Methodology*

©1992 American Sociological Association

JSTOR and the JSTOR logo are trademarks of JSTOR, and are Registered in the U.S. Patent and Trademark Office. For more information on JSTOR contact [jstor-info@umich.edu](mailto:jstor-info@umich.edu).

©2002 JSTOR

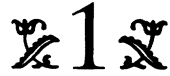

# NOTIONS OF POSITION IN SOCIAL NETWORK ANALYSIS

*Stephen P. Borgatti\**  
*Martin G. Everett†*

*The notion of position is fundamental in structural theory. However, at least two profoundly different conceptions of position exist. The two basic types of position have radically different characteristics, making them appropriate for different theoretical applications. We present examples in which scholars have operationalized one type of position but drawn conclusions as if the other type had been used. We compare the two notions of position in terms of their applicability in several research areas, including power in exchange networks, role theory, world-system theory, and social homogeneity.*

One of the most central concepts in social network analysis and structural theory in general is the notion of position. Position is utilized as a dependent or independent variable in a variety of empirical and theoretical works. For example, position plays a critical role in the study of world systems (Snyder and Kick 1979; Breiger 1981; Nemeth and Smith 1985); adoption of innovation, diffusion, and other social homogeneity phenomena (Burt 1978, 1987; Rogers 1979; Friedkin 1984; Anderson and Jay 1985); and power in exchange networks (Cook et al. 1983; Markovsky, Willer, and Patton

We thank Katherine Faust, Linton Freeman, Noah Friedkin, Peter Marsden, and John Skvoretz for helpful comments on earlier drafts. We also thank the anonymous reviewers for many excellent suggestions.

\*University of South Carolina

†Thames Polytechnic, London

1988). Position has also been related to similarity in attitudes (Erickson 1988); mental health (Kadushin 1982); economic success in interorganizational networks (Burt 1979); perception of leadership (Leavitt 1951); political solidarity (White, Boorman, and Breiger 1976); job changes (Krackhardt and Porter 1986); production of scientific knowledge (Brym 1988); growth of cities (Pitts 1978); organizational influence (Galaskiewicz and Krohn 1984); and many others.

However, the term *position* refers to more than one concept. A variety of different formal definitions exist, and an even greater variety of operational implementations of these definitions may be found in the form of relaxed definitions, algorithms, procedures, computer programs, and the like. These myriad variants can yield more than just different numerical results: Many must be interpreted quite differently and demand that different causal mechanisms be posited. Yet, as a rule, the substantive and theoretical literature that has utilized the notion of position has not done this. In fact, as we shall demonstrate, published works frequently define position one way and then proceed to draw conclusions as if a different definition had been used.

In this paper, we suggest that there are two fundamental types of positional notions that underlie the observed variety. To simplify the exposition, we select a single prototypical representative of each type to describe in detail. We then compare the applicability of each across several areas of research, including power in exchange networks, world-systems theory, roles and social structure, and social homogeneity. We conclude with a look at the deeper notions of structure that underlie the different approaches to the concept of position.

It should be emphasized that our discussion pertains to the idealized, mathematical formalizations of the positional notions, not to the actual algorithms and computer programs that implement them. This distinction is not problematic, however, since all valid algorithms and programs reach the same solutions when applied to perfect, error-free data; they differ only in the way they handle departures from mathematical ideals.

## 1. BASIC NOTIONS

The fundamental idea underlying the notion of position is that of structural correspondence or similarity. Actors who are connected

in the same way to the rest of the network are said to be equivalent and to occupy the same position. In general, the objective of positional analyses is to partition actors into mutually exclusive classes of equivalent actors who have similar relational patterns. This positional approach to network analysis is intended to contrast with the relational or cohesive approach (Burt 1978; Friedkin 1984), which attempts to find subsets of actors who are strongly or closely related to each other. In the first case the underlying clustering principle is similarity; in the second, it is cohesion or proximity.

However, there are at least two fundamentally different ways of interpreting the phrase *connected in the same way to the rest of the network*, which depend on whether one wishes to take the phrase literally or metaphorically. The distinction is illustrated by the following problem, adapted from Hofstadter (1985). Consider the following two abstract structures:

$$A = \langle 1 \ 2 \ 3 \ 4 \ 5 \ 5 \ 4 \ 3 \ 2 \ 1 \rangle \quad \text{and} \quad B = \langle 0 \ 1 \ 2 \ 3 \ 4 \ 4 \ 3 \ 2 \ 1 \ 0 \rangle .$$

Hofstadter asks, “What is to *B* as 4 is to *A*? Or, to use the language of roles: What plays the role in *B* that 4 plays in *A*?” (p. 549). According to Hofstadter, an overly literal, concrete answer is 4, whereas a more natural, more analogical response is 3. More formally, the distinction is analogous to the distinction made in mathematics and logic between identity/equality and isomorphism/similarity. For example, in algebra, two binary relations are equal or identical if they contain the same ordered pairs, but they are isomorphic if there is a one-to-one correspondence between the pairs of each relation. Similarly, two semigroups are the same if they relate the same compound relations in the same ways, but they are isomorphic if there is a one-to-one correspondence between their multiplication tables. In geometry, two triangles are equal if corresponding sides are the same length, but they are similar if they are proportional to each other. In the case of networks, the distinction corresponds to Faust’s (1988) distinction between *structural equivalence*<sup>1</sup> (Lorrain and White 1971; Burt 1976;

<sup>1</sup>It is unfortunate that Lorrain and White used the term *structural equivalence* to name their particular species of positional concept, because the term connotes a much broader notion of position than was actually defined. As will become apparent, their concept would have been more aptly named *structural equality* or *structural identity* or even *label equivalence*. It is important to keep in mind that despite appearances, *structural equivalence* refers to a specific definition of position, not to the general principle of structural similarity.

Breiger, Boorman, and Arabie 1975) and *general equivalences*, and to Pattison's (1988) distinction between structural equivalence and *abstract equivalences*. The general or abstract equivalences referred to include *automorphic equivalence* or *structural isomorphism* (Everett 1985; Winship 1988), *regular equivalence* (White and Reitz 1983; Borgatti and Everett 1989), and a variety of others (Winship and Mandel 1983; Breiger and Pattison 1986; Hummell and Sodeur 1987). The concepts of structural, automorphic, and regular equivalence are listed in order of increasing generalization: Any pair of nodes that is structurally equivalent is also necessarily automorphically and regularly equivalent, and any pair of automorphically equivalent nodes is also regularly equivalent.<sup>2</sup>

As Pattison (1988) noted, there are important differences among all the abstract equivalences, but the fundamental distinction is between structural equivalence and all the others. Of the others, the one most comparable to structural equivalence in definition and application is structural isomorphism (automorphic equivalence). For this reason, in the interests of clarity and simplicity, we focus our discussion only on the contrast between structural equivalence and automorphic equivalence.

## 2. TECHNICAL DEFINITIONS AND NOTATION

For convenience, all examples in this paper concern non-valued networks defined by a single relation. The restriction is not necessary but significantly simplifies the exposition. Networks are represented as graphs denoted  $G(V,E)$ , where  $V$  refers to a set of vertices, nodes, points, or actors, and  $E$  refers to a set of edges, lines, links, ties, or relationships. When discussing the vertex sets of two graphs,  $G$  and  $H$ , we use  $V(G)$  to refer to the vertex set of graph  $G$  and  $V(H)$  to refer to the vertex set of graph  $H$ . Similarly,  $E(G)$  refers to the edge set of graph  $G$  and  $E(H)$  to the edge set of graph  $H$ .

The notation  $P(a)$  is used to denote the position of node  $a$  in a network. The position of a node is a categorical attribute of that node, which can be thought of as its color (Everett and Borgatti

<sup>2</sup>It should also be noted that regular equivalence actually defines a lattice of distinct equivalences (Borgatti and Everett 1989), which includes structural and automorphic equivalence.

1990) or flavor. By a slight abuse of notation, we also let  $P(\{a,b \dots\}) = \{P(a) \cup P(b) \cup \dots\}$ . In other words, if  $S$  is a set of nodes,  $P(S)$  is the set of distinct positions occupied by the nodes in  $S$ .

In a directed graph, the notation  $N^i(a)$  denotes the set of nodes that  $a$  receives ties from and is defined as  $N^i(a) = \{c: (c,a) \in E\}$ . The notation  $N^o(a)$  denotes the set of nodes that  $a$  sends ties to and is defined as  $N^o(a) = \{c: (a,c) \in E\}$ . We refer to  $N^i(a)$  and  $N^o(a)$  as the *in-neighborhood* and *out-neighborhood* of  $a$ , respectively. The neighborhood of a point,  $N(a)$ , is defined as the ordered pair  $N(a) = (N^i(a), N^o(a))$ .

In an undirected graph, the neighborhood  $N(a)$  is defined as the set of nodes directly connected to node  $a$ , so that  $N(a) = \{c: (a,c) \in E\} = \{c: (c,a) \in E\}$ .

A *structural* or *graph-theoretic attribute* is any attribute of a node or graph that makes no reference to the names or labels of the nodes in the graph. For example, in an undirected graph representing friendships among a set of people, the property of being no more than three links distant from any node is a structural attribute of a node, but the property of being no more than three links distant from Mary is not a structural attribute. The centrality of a point is a structural attribute, as is the property of belonging to seven cliques of size 4, but belonging to three cliques that include Bill as a member is not a structural attribute.

### 3. POSITION AS STRUCTURAL EQUIVALENCE

The term *structural equivalence* was coined by Lorrain and White (1971), who defined it this way:

Objects  $a, b$  of a category  $C$  are *structurally equivalent* if, for any morphism  $M$  and any object  $x$  of  $C$ ,  $aMx$  if and only if  $bMx$ , and  $xMa$  if and only if  $xMb$ . In other words,  $a$  is structurally equivalent to  $b$  if  $a$  relates to every object  $x$  of  $C$  in exactly the same ways as  $b$  does. From the point of view of the logic of the structure, then,  $a$  and  $b$  are absolutely equivalent, they are substitutable. (P. 81)

Today, however, the term is used to refer to a much simpler<sup>3</sup> concept. The modern usage is due to Burt (1976), who defined a set of structurally equivalent nodes as a set of nodes connected by the same relations to exactly the same people. Thus, an actor's position is defined by *who* he or she is connected to. It is literally and concretely the set of actors with whom he or she has direct contact. In the notation given in the previous section,  $P(v) = N(v)$  for all  $v \in V$ . If we ask, What is Bill's position in the network?, we are asking nothing more than, Who is Bill directly connected to?

Applied to nonvalued graphs, Burt's definition can be elegantly stated as follows: If  $G = \langle V, E \rangle$  is a graph and  $a, b \in V$ , then  $P(a) = P(b)$  iff  $N(a) = N(b)$ . The definition says that two actors in a network occupy the same position if and only if they have perfectly overlapping neighborhoods. In other words, they have identical ego networks. By *identical* we mean not only that the ego networks contain the same individuals, but that, consequently, they also contain the same relationships among them. As shown in Figure 1, the only difference between the ego networks of structurally equivalent actors like Bill and Joe is the name or label of the two egos.

It should be noted that our rewritten definition reproduces a small but important shortcoming in Burt's definition, which also occurs in Lorrain and White's original. The problem is that for graphs without reflexive loops, none of these definitions allows nodes that are connected to each other to occupy the same position. Thus, in Figure 1a, Mary and Jane are not structurally equivalent by these definitions. A better definition is  $P(a) = P(b)$  iff  $N(a) - \{a, b\} = N(b) - \{a, b\}$ . However, this version fails when a single directed arc links  $a$  and  $b$ . For example, in Figure 2, nodes  $a$  and  $b$  would be considered

<sup>3</sup>The difference between the formulations may not be apparent from the definitions. What Lorrain and White intended is something akin to the following simplified recipe. Start with a handful of observed relations. Call these generators. Using relational composition and some rules for determining when two relational products are the same, create a semigroup of relations. Determine which nodes have ties to the same actors on these new compound relations (not necessarily the generators). Call these structurally equivalent. It is important to realize that in Lorrain and White's formulation, structurally equivalent nodes need not have ties to the same alters on the *observed* relations, as Burt's definition requires, but they must always have ties to the same alters on certain derived relations.

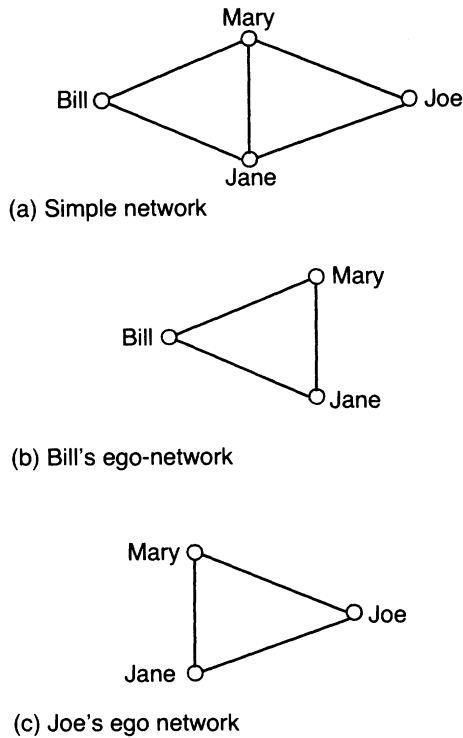

FIGURE 1.

structurally equivalent by this definition. The definition also fails to distinguish nodes with reflexive loops from ones without.<sup>4</sup>

Since structurally equivalent actors are connected to exactly the same nodes, they are identical with respect to all structural variables. They have the same centrality, eccentricity (Harary 1969), degree, prestige, etc. In fact, any graph-theoretic statement that can be said about one actor can be said about the other. The converse, however, is not true. Actors who are indistinguishable on absolutely all graph-theoretic attributes are not necessarily structurally equivalent. For example, in Figure 3, nodes *a* and *h* are absolutely identical with respect to all possible graph-theoretic variables, but they are not structurally equivalent because they do not have the same neighborhoods.

<sup>4</sup>A definition that works in most cases was given by Burt (1987, p. 1330). A definition that works in all cases was given by Everett, Boyd, and Borgatti (1990). In their definition,  $P(a) = P(b)$  iff  $\exists \pi \in \text{Aut}(G)$  such that  $\pi = (a\ b)$  and  $\pi(a) = b$ , where  $\text{Aut}(G)$  denotes the automorphism group of a graph  $G$ .



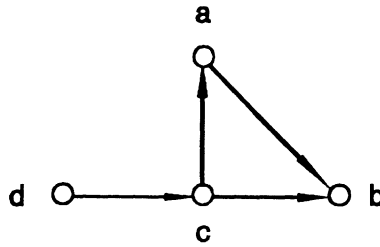

**FIGURE 2.** Graph containing no structurally equivalent nodes.

As Lorrain and White (1971, p. 82) pointed out, for a given set of relations, the notion of structural equivalence is a wholly *local* concept: To know whether two actors are equivalent, we only need to know who they are directly connected to. We do not require any knowledge of the rest of the network. Consequently, an actor's position is utterly unaffected by any changes in the network that occur more than one link away.<sup>5</sup> As a practical matter, this means that structural equivalence can be calculated on incomplete data sets, provided that no data that pertains to a given pair of individuals' ego networks is missing. In contrast, global variables, such as betweenness centrality (Freeman 1978) or abstract equivalences, are miscalculated if any ties, no matter how distal, are missing.

It also means that structural equivalence is not truly a relational concept in the sense of Wellman (1988) or a structural concept in the sense of Krippendorff (1971), because the entire network need

<sup>5</sup>Of course, if the researcher computes structural equivalence not on the raw data but on a derived dataset that encodes more than simple adjacency, then even remote changes in the original network could affect the measurement of the degree of structural equivalence of a given pair of actors. For example, Burt (1976) suggested computing structural equivalence on the geodesic distances among actors in a network. However, three points should be noted. First, this is not a theoretical issue: No changes in the network at more than two links away can ever affect the determination of whether a given pair of actors is equivalent or not equivalent in the ideal sense given by the definition of structural equivalence. It is only practical algorithms intended to detect structural equivalence in imperfect empirical data that are affected. Second, perfectly equivalent actors will not be affected by remote changes. The issue arises only when we compute a measure of the extent of structural equivalence *among actors who are not structurally equivalent*. Third, and most important, using derived datasets such as geodesic distance matrices can change results but not the essential nature of structural equivalence: It remains a local concept even if the data are somehow "global."

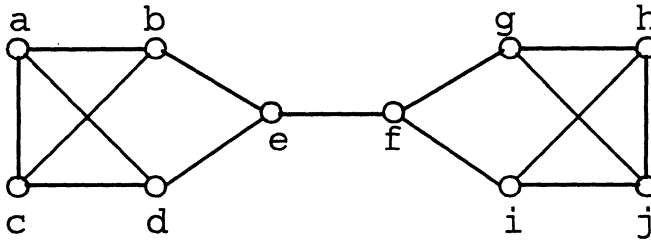

FIGURE 3. Graph in which all points have equal degree.

not be involved for one to evaluate the status of a given actor. Instead, one need collect only ego network data, which is not fundamentally different from collecting traditional “attribute” data (Wellman 1988) like marital status or number of children.

A consequence of the local nature of structural equivalence is that sets of structurally equivalent actors are always fully contained within components of a graph. That is, actors located in different components of a disconnected graph (or in different graphs) can never be structurally equivalent (except isolates). In fact, as a general rule, nodes cannot be structurally equivalent if they are more than two links apart. Exceptions occur only for isolates, which satisfy structural equivalence vacuously, and for directed graphs, in which case the rule refers to links without regard for direction (i.e., to semipaths). Hence, cohesion/proximity is part and parcel of the notion of structural equivalence. For undirected graphs, this means that sets of structurally equivalent actors form a cohesive subset, specifically a 2-clique (Luce 1950), which is a well-known formalization of the general notion of a cohesive subset.<sup>6</sup> Although the fact that structurally equivalent actors form cohesive subsets has often been noticed empirically (Friedkin 1984; Burt 1978, 1987), the literature has in general regarded sets of structurally equivalent actors as fundamentally different from cohesive subsets (e.g., DiMaggio 1986; Hartman and Johnson 1990), rather than as a special type of cohesive subset, which, mathematically, they are.

<sup>6</sup>Another method of detecting subgroups in graphs, which also succeeds in finding sets of structurally equivalent actors, is based on multidimensional scaling of the graph-theoretic distance matrix of a graph (Burt 1982, p. 71). Because structurally equivalent actors are the same distances from all other nodes, this method assigns the same map coordinates to all structurally equivalent nodes.

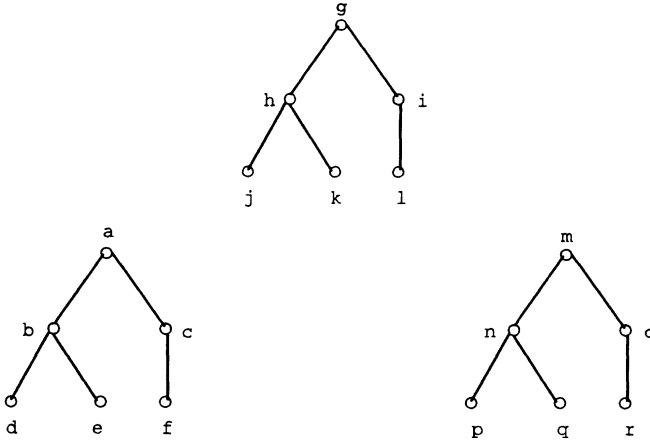

FIGURE 4. Disconnected graph.

Ultimately, the structural equivalence conception of position is about the *location* of an actor in a labeled graph. Structurally equivalent actors share the same location. From this perspective, it is not difficult to see why sets of structurally equivalent actors form cohesive subsets: Both concepts are based on detecting actors who occupy the same or nearly the same locations, neighborhoods, or regions of a network. It is also obvious that two nodes occupying the same location in a labeled graph share two fundamental and logically distinct properties: proximity and similarity. The difference is illustrated in Figure 4, in which a disconnected graph represents certain relations among coworkers in a formal organization. Each component is a different office or subsidiary. While points  $a$ ,  $g$ , and  $m$  are similar in their patterns of connection, they are not at all proximate. Conversely, the points  $a$ ,  $b$ ,  $c$ ,  $d$ ,  $e$ , and  $f$  are relatively proximate, but they are not similar. However, points  $d$  and  $e$ , which are structurally equivalent, are both proximate and similar.

#### 4. POSITION AS STRUCTURAL ISOMORPHISM

Since automorphic equivalence depends crucially on the notion of isomorphism, we use the terms *automorphic equivalence* and *structural isomorphism* interchangeably. The notion of isomorphism is fundamental in many branches of mathematics, including graph

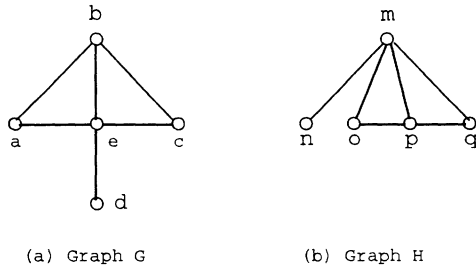

FIGURE 5. Graphs  $G$  and  $H$  are isomorphic.

theory. An isomorphism is a one-to-one mapping of one set of objects to another such that the relationships among the objects are also preserved. A graph isomorphism between two graphs  $G$  and  $H$  is a mapping  $\pi:G \rightarrow H$  such that for all  $a, b \in V(G)$ ,  $(a, b) \in E(G) \leftrightarrow (\pi(a), \pi(b)) \in E(H)$ . In other words, a graph isomorphism is a mapping of the nodes in one graph to corresponding nodes in another graph such that if two nodes are connected in one graph, then their correspondents in the second graph must also be connected. Two graphs are isomorphic if there exists an isomorphism that relates them. For example, the two graphs in Figure 5 are isomorphic because the mapping  $\pi_1:G \rightarrow H$  (Table 1) is an isomorphism.

Isomorphic graphs are identical with respect to all graph-theoretic attributes. If a graph has twelve cliques of size 3 and ten cliques of size 4, then all graphs isomorphic to it also have twelve cliques of size 3 and ten cliques of size 4. The only possible differences between isomorphic graphs are the labels of the nodes and edges (if any).

TABLE 1  
The Graph Isomorphism  
 $\pi_1:G \rightarrow H$ , Relating the  
Graphs in Figure 5

$g$	$\pi_1(g)$
$a$	$o$
$b$	$p$
$c$	$q$
$d$	$n$
$e$	$m$

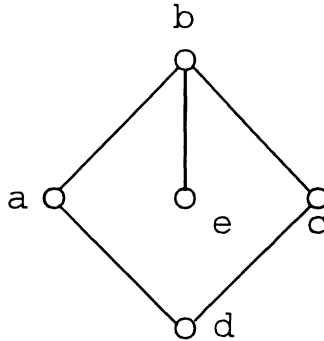

Graph K

**FIGURE 6.** Graph  $K$  is not isomorphic with any graph in Figure 5.

In fact, one way to think about isomorphic graphs is that without labels on the nodes or edges, they would be indistinguishable. If we removed the labels on the graphs in Figure 5, then picked the graphs up off the paper, shuffled them randomly, and then put them back on the paper, we would not be able to tell which graph was which. Nor, from a structural point of view, would it matter, since the graphs have the same structure.

On the other hand, graph  $K$  in Figure 6 is distinguishable from the graphs in Figure 5, even without the labels. Graphs  $H$  and  $G$  have a node with degree 4 while graph  $K$  does not. Note that it is not an issue of how the graphs are drawn (since the way a graph is drawn is arbitrary), but how they are structured, the pattern of their connections.

All graphs are isomorphic with themselves. That is, for all graphs, we can find a mapping  $\pi: G \rightarrow G$  such that  $\pi$  is an isomorphism. An isomorphism of a structure with itself is known as an *automorphism*. Obviously,  $\pi$  can always be the identity mapping, where for all  $v \in V$ ,  $\pi(v) = v$ . However, it is often the case that there exists an automorphism of  $G$  that is not the identity. For example, the graph in Figure 3 has three nontrivial automorphisms, which are visible as symmetries of the graph. One can see that if the labels were removed from the graph, a  $180^\circ$  rotation of the graph along the horizontal axis would be indistinguishable from the original. Similarly, a  $180^\circ$  rotation around the vertical axis would also leave the

TABLE 2  
All Automorphisms of the Graph in Figure 3

$v$	$\pi1(v)$	$\pi2(v)$	$\pi3(v)$	$\pi4(v)$
$a$	$h$	$c$	$j$	$a$
$b$	$g$	$d$	$i$	$b$
$c$	$j$	$a$	$h$	$c$
$d$	$i$	$b$	$g$	$d$
$e$	$f$	$e$	$f$	$e$
$f$	$e$	$f$	$e$	$f$
$g$	$b$	$i$	$d$	$g$
$h$	$a$	$j$	$c$	$h$
$i$	$d$	$g$	$b$	$i$
$j$	$c$	$h$	$a$	$j$

graph unchanged. The third automorphism is a composition of the other two. Table 2 gives all automorphisms of the graph.

Two nodes  $a$  and  $b$  in a graph  $G$  are *structurally isomorphic* or *automorphically equivalent* if there exists an isomorphism  $\pi:G \rightarrow G$  such that  $\pi(a) = b$ . Two actors occupy the same position if they are isomorphic. Sets of isomorphic actors are called *orbits*. In Figure 3, the orbits are  $\{a,c,h,j\}$ ,  $\{b,d,g,i\}$ , and  $\{e,f\}$ . In contrast, the set of structurally equivalent points are  $\{a,c\}$ ,  $\{b,d\}$ ,  $\{g,i\}$ , and  $\{h,j\}$ .

Whereas the structural equivalence approach views two actors as occupying the same position only if they are connected to the same alters, the structural isomorphism approach (like regular equivalence) views actors as occupying the same position if they are connected to corresponding others. That is, if actors  $a$  and  $b$  are isomorphic, then for all  $c \in V$ ,  $(a,c) \in E$  implies there exists a node  $d$  isomorphic to  $c$  such that  $(b,d) \in E$ . Putting it another way, whereas the neighborhoods of structurally equivalent points contain the same actors, the neighborhoods of isomorphic actors contain the same positions. Technically, in the structural equivalence approach,

$$P(a) = P(b) \rightarrow N(a) = N(b),$$

whereas in the isomorphic and regular equivalence approaches,<sup>7</sup>

<sup>7</sup>It should be noted that this equation is true of structurally isomorphic nodes, but it is not a definition of automorphic equivalence. See Everett and Borgatti (1990) for details.

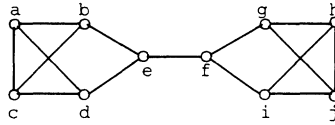

(a) Labels identify nodes

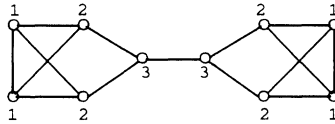

(b) Labels identify positions

**FIGURE 7.** Neighborhoods of isomorphic nodes contain the same positions, not the same nodes.  $N(a) = \{b, c, d\}$ , while  $N(h) = \{g, i, j\}$ , yet  $P(N(a)) = P(N(h)) = \{1, 2\}$ .

$$P(a) = P(b) \rightarrow P(N(a)) = P(N(b)).$$

Thus, in this approach, if actor  $a$  occupies the same position as actor  $b$ , then the set of positions that  $a$ 's alters occupy is the same as the set of positions that  $b$ 's alters occupy. An illustration is provided in Figure 7. Furthermore, the ego networks of isomorphic actors are also isomorphic. Not only is there a one-to-one correspondence between the nodes of each ego network, there is another one-to-one correspondence between the lines among them.

Like structurally equivalent nodes, isomorphic nodes are absolutely identical with respect to all structural variables. For example, in Figure 7a, nodes  $a$ ,  $c$ ,  $h$ , and  $j$  all have the same closeness centrality (Freeman 1978), graph-theoretic power index (Markovsky, Willer, and Patton 1988), prestige (Knoke and Burt 1983), and eccentricity (Harary 1969). They participate in exactly the same number of 2-clans, 3-cliques, and 4-clubs (Mokken 1979). They are connected to precisely the same number of nodes at distance 3. Unlike the case of structural equivalence, the converse is also true: All nodes that are identical with respect to all possible structural variables are necessarily isomorphic.

One way to think about isomorphic nodes is to remove the node labels from a graph, as in Figure 8a, to get an unlabeled graph, as in Figure 8b. Then imagine picking the unlabeled graph up off the

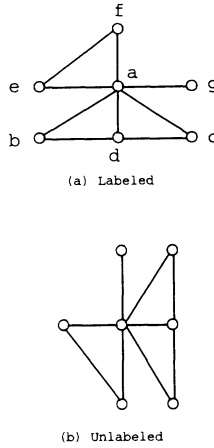

FIGURE 8. Labeled graph and underlying unlabeled graph.

paper, spinning it around a few times, and putting it down on a fresh piece of paper. Could we tell which node is which? Some nodes are obvious. Node *a*, for example, is easy to identify because it is the only node incident with six lines. Nodes *b* and *c*, in turn, are impossible to distinguish from each other but easy to distinguish from other nodes. A more interesting example is the graph in Figure 7a. In this graph, all nodes have equal degree. But no matter how the graph is drawn, certain structural differences among the nodes will be apparent. For example, whereas some nodes (*a*, *c*, *h*, and *j*) are five links distant from other nodes, two nodes (*e* and *f*) are no more than three links distant from any other nodes.

Unlike structural equivalence, structural isomorphism is independent of proximity. Isomorphic nodes may be adjacent, distant, or completely unreachable from each other. In a disconnected graph, nodes located in different components can be isomorphic, as shown in Figure 4. If the data in Figure 4 refer to relationships among coworkers in a formal organization, the components may refer to different offices or subsidiaries. Using structural isomorphism we can detect the similarity in position held by points *a* and *g*, or *b* and *h*.

In sum, structural equivalence and structural isomorphism are fundamentally different approaches to the notion of position. In the structural equivalence approach, position is seen quite literally as a location in a labeled graph. It is about identifying *who* an actor is



directly connected to. In contrast, the structural isomorphism approach sees position as a location in an unlabeled graph. Since, by definition, nodes are not identifiable in an unlabeled graph except by the pattern of connections in which they are embedded, the location of a node in an unlabeled graph is the sum total of all structural characteristics that can be calculated for that node. It is, ultimately, the *way* in which the node is connected to others. If structurally equivalent actors occupy the same location, structurally isomorphic actors occupy analogous or isomorphic locations.

Abstracting a bit, we could say that in the structural equivalence approach, the network or labeled graph represents the underlying structure of a group; hence, an actor's location in that structure represents his or her position in the group. In contrast, in the structural isomorphism approach, the structure of interest is not the labeled graph itself, which is seen as the observed or "surface structure," but the structure of the surface structure, which is the unlabeled graph that underlies the labeled graph. It is the actor's location in this "deep structure," then, that represents his or her position in the group. Thus, structural equivalence is to labeled graphs what structural isomorphism is to unlabeled graphs. In the absence of a particular substantive application, we suggest that the choice between structural equivalence and structural isomorphism as measures of position rests entirely on which of the labeled or unlabeled representations best corresponds to one's intuitive concept of what *structure* means.

It is important to note that the difference between automorphic and structural equivalence is conceptual, theoretical, and fundamental: It is not that one is an approximation or computer-implementation of the other. We have found in informal discussions with colleagues that some believe that the purpose of algorithms like CONCOR (Breiger, Boorman, and Arabie 1975) and computer programs like STRUCTURE (Burt 1989) is to relax structural equivalence to get something akin to automorphic equivalence. This is not the case, as is easily verified by running a network such as Figure 3 through all these programs. Such programs do relax the definition of structural equivalence, but only to allow nodes that are not perfectly equivalent (i.e., that do not share absolutely every alter) to be considered equivalent; they will not find such points as *a* and *h* at all equivalent. Similarly, programs for computing regular equivalence, such as REGE (D. R. White 1984), and automorphic equivalence,

such as MAXCORR (Borgatti 1987) or NSIM (Everett and Borgatti 1988), also relax their respective definitions, but the results will not resemble the output of CONCOR or STRUCTURE.

## 5. THE USE OF POSITION IN STRUCTURAL THEORY

In this section we consider ways in which the notion of position has been used in structural theory and discuss which type of position is best suited for each specific application. In the process, we give examples where the literature has confounded the two types of position, using structural equivalence for data analysis but interpreting results as if structural isomorphism had been used instead.

### 5.1. *Status/Role Systems*

Many authors (Lorrain and White 1971; Burt 1982; Sailer 1978; Winship and Mandel 1983; Faust 1988) have seen network equivalences as formalizations of the hallowed sociological concepts of status, position, role, and role-set.<sup>8</sup> Nadel (1957), Merton (1959), and Linton (1936) have all discussed social structure in terms of a “pattern or network (or ‘system’) of relationships obtaining between actors in their capacity of playing roles relative to one another” (Nadel 1957, p. 12). This relational approach to social structure, as distinguished from a normative approach, emphasizes that what defines a role, such as that of nurse, is precisely the characteristic set of relationships that actors who are nurses have with actors who are doctors, patients, suppliers, secretaries, other nurses, and so on, just as doctors are defined by their relationships with actors playing all the other roles. Society is a network of relationships among individuals, and social structure is an underlying network of relationships among roles or positions.

An illustration is given in Figure 9. Figure 9a records advice/order-giving relations among individuals in a doctor’s office. Figure 9b collapses structurally similar actors (under both structural equivalence and isomorphism) into positions and records relations among the positions. Figure 9a describes the manifest society, while Figure 9b describes the underlying social structure.

<sup>8</sup>We use the terms *role*, *status*, and *role-set* synonymously, since their differences do not bear on the issues of this paper.

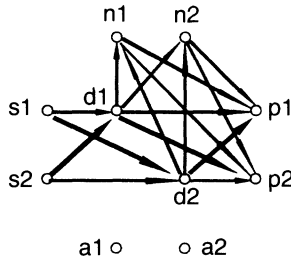

(a) The “gives information about medicine” relation

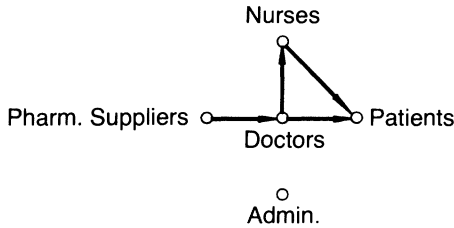

(b) Relations among positions

**FIGURE 9.** Relations in a doctor’s office.

Note that in this example, both structural equivalence and isomorphism yield the same position, so they are equally applicable. In Figure 10, however, we have a slightly different doctor’s office in which each doctor has his or her own nurse and patients. Now the doctors are no longer structurally equivalent, although they remain isomorphic. Figure 11a collapses structurally equivalent nodes into positions. Note that we no longer have a single position corresponding to the role of doctor, nor a single position corresponding to the role of secretary. In contrast, Figure 11b collapses structurally isomorphic nodes, yielding the same social structure as in Figure 9b.

As models of roles and social structure in general, structural equivalence and isomorphism are clearly different: According to structural equivalence, two actors must have the same relationships with the same *individuals* to be regarded as playing the same role, whereas according to structural isomorphism, they must have the same relationships with counterparts who are playing the same roles.

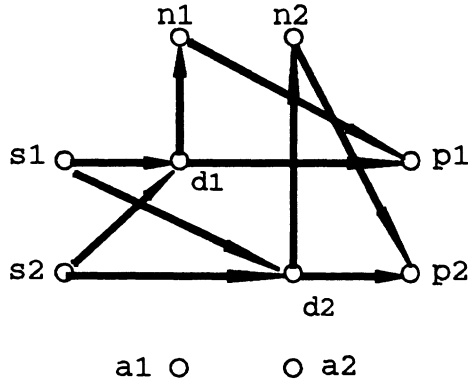
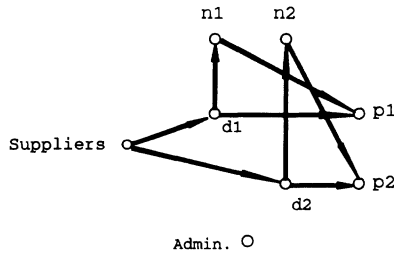

FIGURE 10. The “gives information about medicine” relation.

In other words, structural equivalence requires that two mothers have the *same* children to both be called mothers, and that two doctors have the same patients, nurses, and secretaries to both be doctors. Structural isomorphism, on the other hand, requires only that two mothers have the same relationships with their own children, and that two doctors have the same relationships with their own patients, nurses, and secretaries.

Hence, if we are interested in modeling social roles in the sense of Nadel and Merton, we must choose structural isomorphism over structural equivalence.<sup>9</sup> Even better, we should prefer a generalization of structural isomorphism, such as iterated automorphic equivalence (Everett et al. 1990) or regular equivalence. Substantively, the principal difference between structural isomorphism and regular equivalence is in the way in which quantities of ties are handled. For example, according to structural isomorphism, a mother with one child is different from a mother with 10 children, but according to regular equivalence, they are the same. Thus, regular equivalence can be used to get at more abstract aspects of roles. Which specific abstract equivalence is needed is not the issue here: The important point is that

<sup>9</sup>However, if one is interested in a more circumscribed notion of role, structural equivalence may be the most appropriate. For example, mothers and fathers of the same children jointly play the role of parent to those particular children, and they are structurally equivalent. Similarly, siblings are children of the same parent and are structurally equivalent.



(a) Structurally equivalent positions

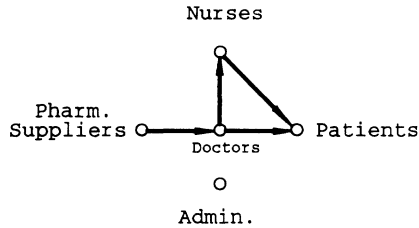

(b) Structurally isomorphic positions

**FIGURE 11.** Relations among positions in a doctor's office.

all are preferable to structural equivalence, which is not designed to model this sort of phenomenon.

Historically, however, researchers needing to operationalize concepts of social role, status, and role-set have employed structural equivalence. For example, in analyzing networks of supreme courts, Caldeira (1988, p. 46) claimed, "Even more important, if a researcher uses structural equivalence as a criterion, he can identify positions, or sets of individuals, that correspond to social roles in the network of communication." This misidentification of structural equivalence with social roles and positions is particularly unfortunate because role theory is often used as a template for building theory about a variety of social phenomena. Studies relying upon such concepts then mistakenly use structural equivalence to operationalize the key variable. For example, several authors (Evan 1966; Burt 1979; Galaskiewicz and Krohn 1984; DiMaggio 1986; H. C. White 1988) have seen economic systems and interorganizational networks as role systems. As Galaskiewicz and Krohn (1984) put it,

A key concept in our study is the social role. . . . Two actors are in the same relative position in social space, i.e., have the same role, to the extent that they have similar relationships to others in the social arena or fields. . . . To phrase this in the context of resource dependency theory, two actors occupy the same structural position, i.e., role in the network, to the extent that they are dependent upon the same organizations for the procurement of needed input resources and the same actors are dependent upon them for their output resources. (Pp. 528–29)

Galaskiewicz and Krohn went on to use structural equivalence to identify organizational roles (p. 532). Another example is provided by Burt (1979), who described economic sectors as sets of structurally equivalent positions:

An economy can be discussed as a network of economic transactions, relations, between corporate actors; an interorganizational network of sales and purchases. The division of labor ensures a high level of redundancy in this network. Those actors engaged in the production of similar goods will have similar relations from other actors (i.e., will require similar proportions of goods as inputs from suppliers) and will have similar relations to other actors (i.e., will offer similar types of goods as outputs to consumers). Viewing the economy as an interorganizational network, those firms producing similar types of goods are structurally equivalent and so jointly occupy a single “position” in the economy. The economic transactions between individual firms therefore can be aggregated into relations between groups of structurally equivalent firms so as to create a topological model of the economy. In the terminology of the Bureau of the Census, these structurally equivalent firms constitute “sectors” of the economy, or “industries” in the economy. (P. 417)

However, since firms in a given sector may purchase from similar suppliers but not necessarily from the *same* suppliers, and

since they may sell to similar clients but not necessarily to the *same* clients, structurally equivalent firms cannot possibly constitute sectors, though structurally isomorphic (and particularly regularly equivalent) firms might. Empirical studies hoping to confirm hypotheses based on the kind of reasoning used by Burt will fail if they operationalize position as structural equivalence. It is important to note that there is nothing wrong with either the proposed image of an economy or the notion of structural equivalence in themselves: It is merely that the latter cannot be used as a model for the former.

Similarly, Snyder and Kick (1979) used role theory to justify their use of structural equivalence to define positions of nations in the world economy. Since world system/dependency theory uses concepts of position and role (Wallerstein 1974), and since structural equivalence has been claimed to find positions and roles, it is not surprising that someone would use structural equivalence to operationalize world system theory. The problem, of course, is that two nations that occupy the same position (say, "core") may have similar relations with other positions (say, "periphery"), but not necessarily the same nations. This point is also made by Smith and White (1986). For example, nation A might purchase certain agricultural products from Guatemala, electronic products from Japan, and engineering expertise from Germany. Nation B might purchase agricultural products from Honduras, electronic goods from Taiwan, and engineering from France. If it happens that Guatemala and Honduras occupy the same position in the world system, and Japan and Taiwan and, separately, Germany and France do as well, then from the point of view of a role system, A and B exhibit the same relational pattern and so play the same role. But from the point of view of structural equivalence, A and B are completely unlike.

It is not unusual in the literature for researchers to use structural equivalence programs to process their data but then to justify and explain the method as if structural isomorphism were used instead. For example, DiMaggio (1986) used structural equivalence to identify organizations with similar organizational fields:

The alternative means of partitioning a population on the basis of observed relations among the population's members is to divide the population into structurally equivalent positions: Organizations in each

subset (or block) share similar relations with organizations in other blocks whether or not they are connected to one another. Imagine a population of organizations connected by flows of personnel and information. One subset of this population (A) recruits personnel from and provides information to another subset of the population (B). Organizations in Subset A never exchange information or personnel with one another, nor do organizations in Subset B. Organizations in each subset exchange only with organizations in the other; but, within the subset with which they exchange, their choices of partners are random. (P. 344)

It is DiMaggio's final sentence that is of particular interest, since it is certainly false if applied to structural equivalence but potentially true if applied to structural isomorphism. From the perspective of philosophy of science, it is interesting to note that three types of systems are implied by DiMaggio's discussion. First, there is the "real" interorganizational network in which individual organizations have links of various kinds with other individual organizations. Second, there is the simplified model of the researcher, in which underlying types of organizations (positions) are hypothesized such that all organizations of one type have the same set of relations with organizations of other types, though not necessarily with the same individual organizations. Third, there is the operationalization of this model via structural equivalence. In most scientific research, the deepest problems probably occur in the generation of the second system, which is essentially a theory or explanation of the observed relationships. However, in DiMaggio's case, the problem occurs with the third system, in which the theory is incorrectly operationalized.

### *5.2. Power in Experimental Exchange Networks*

There are two well-known streams of work in this area, represented by the work of Cook et al. (1983), on the one hand, and the work of Markovsky et al. (1988), on the other. Since both use the notion of position in the same way, for our purposes it suffices to describe only the first approach.



The explicit objective of Cook et al. is to investigate structural power: The power that one individual has over another is a function of the extent to which each is dependent on the other for unnamed goods (Emerson 1962). Dependency is a function of demand (how much each individual needs the goods that others can provide) and supply (the number of individuals who can supply the goods). In the context of network analysis, demand may be viewed as an internal, individualistic, nonstructural attribute of actors. In contrast, supply may be viewed as an external function of the structural position of a node in the network. To investigate only the structural, supply-side of power, Cook et al. designed their experiments so that all actors had equal demand.

The appropriate notion of position in this context is structural isomorphism. If power, as expressed in these particular experimental designs, is a purely structural attribute, then sets of isomorphic actors must have equal power, since isomorphic actors are by definition identical with respect to all structural attributes. We can think of power in this context as the outcome of a purely structural process (exchange), which cannot contradict the classification of actors by automorphism classes. If it does, then the experimental design has not succeeded in filtering out all the nonstructural elements of the process, such as individual variations in competence, motivation, and resources, of which the latter two are components of the demand side of dependency. In this sense, the notion of structural isomorphism can be used to diagnose the presence of nonstructural elements in a process, in the “same” way that models based on the marginals of contingency tables can diagnose the presence of interactions among variables.

We can infer that both sets of researchers have recognized intuitively that structural isomorphism is the appropriate notion of position in this context because they invariably label positions in a way consistent with isomorphism and inconsistent with structural equivalence. However, this must remain an inference, since they do not address the issue directly. Markovsky et al. (1988) defined position (rather vaguely) as follows:

Positions are network locations occupied by actors.  
A relation between two positions is an exchange opportunity for actors in those positions. In short,

actors occupy positions linked by relations. We will index both actors and position using uppercase letters and at times refer to them interchangeably. (P. 223)

Similarly, Cook and Emerson (1978) provided the following anti-definition:

People in structurally similar locations are said to occupy the same position. We will provide no explicit definition of position until the theory becomes more formal, at which point it will be given a graph-theoretic definition. (P. 725n)

A later paper (Cook et al. 1983) defined position as “a set of one or more points whose residual graphs are isomorphic.” The reason for defining position in this way is left unstated, but as Everett et al. (1990) have shown, it can be regarded as an (inaccurate) approximation to structural isomorphism. Substituting structural isomorphism for their *ad hoc* definition would put that portion of their work on a more solid mathematical foundation.

Structural equivalence would not be an appropriate approach to this position in this case because there is nothing in the (present) theoretical formulation of power in exchange networks that demands that nodes of equal power be connected to precisely the same others. For example, in Figure 12, equal power is predicted by both major theories for all points labeled *E*, even though they are quite distant from each other. It is not that structural equivalence yields wrong predictions (it does not), but that it fails to make most of the predictions that can be made. In this example, all nodes *F* have equal power, but since some are more than one intermediary apart, they are not structurally equivalent, and structural equivalence cannot predict the observed power homogeneity of all *F*s. Similarly, all *E* nodes have equal power, but again structural equivalence cannot predict this, this time because each is connected to nodes that the others are not connected to. In general, structural equivalence reacts to nonstructural elements and hence fails to predict homogeneity for the outcome of any truly structural process.

It is important to note that what makes structural isomor-

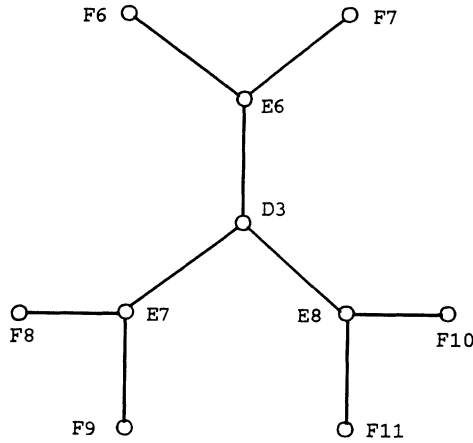

**FIGURE 12.** All nodes labeled with the same letter are expected to achieve similar levels of power. Adapted from Cook et al. (1983, p. 280).

phism the right concept here and structural equivalence the wrong concept is not the phenomenon of power: It may well be that equality of power in natural exchange networks is better predicted by structural equivalence than by structural isomorphism. That is, it may be that collections of actors who are both proximate and structurally similar are the most likely to achieve similar power levels for a host of substantive reasons, including the opportunity for alliance formation. But the way Cook et al. and Markovsky et al. have designed their experiments, the only components of power that are available to the subjects are the purely structural aspects. The aptness of this description is particularly evident in the work of Markovsky et al. They argued that power is a positive function of the number of odd-length, nonintersecting paths, and a negative function of the number of even-length, nonintersecting paths. These are entirely structural attributes. Consequently, in these experiments it does not matter *who* actors are connected to, but *how* they are connected.<sup>10</sup>

<sup>10</sup>A key implication of their results is that a node's power in an exchange network is a global, structural property that depends, recursively, on the power of the node's potential trading partners, which in turn depends on the power of their set of partners, and so on. If a node is connected only to powerful others, it cannot be powerful. This contrasts with Emerson's (1962) simple dependency theory, which implies that the more trading partners an actor has, the greater his or her power.

This is precisely the difference between structural equivalence and structural isomorphism.

More broadly, the important difference between structural isomorphism and structural equivalence is that each implies a different type of mechanism by which homogeneity across subsets of actors with respect to a key substantive outcome is achieved. Structural isomorphism is the right concept for modeling power in experimental exchange networks because the mechanism by which equality of power is achieved is entirely structural and unrelated to proximity. In contrast, structural equivalence is the wrong concept for modeling the outcome of any kind of infectious process, such as homogeneity with respect to gossip heard or diseases suffered, because such processes are not entirely structural and depend crucially on proximity. Conversely, structural equivalence is wrong for modeling any homogeneity that is achieved by a noninfectious type of mechanism.

### *5.3. Social Homogeneity*

In their classic study of innovation, Coleman, Katz, and Menzel (1957) used a network approach to explain adoption of a new drug among physicians. The idea was that while any given physician has a certain probability of adopting a new drug using information he or she may have gathered from manufacturers and published studies, the probability is increased if he or she knows another physician who has already adopted the drug. This relational or cohesive approach asserts that at least one causal mechanism underlying social homogeneity is a process of direct infection or transmission similar to the spread of gossip or disease. This assertion implies that groups of physicians who are closely connected are likely to be more homogeneous with respect to adoption of the new drug than are collections of physicians who are not closely connected. Consequently, we expect co-membership in cohesive subsets such as cliques to predict similar outcomes with respect to adoption.

There has been some interest in the literature (Burt 1978; Burt and Doreian 1982; Friedkin 1984; DiMaggio 1986; Burt 1987; Erickson 1988; Hartman and Johnson 1990) in evaluating whether the cohesive or the positional approach is the better predictor of certain forms of social homogeneity. At the substantive level, the question is which is the most effective mechanism of achieving homogeneity: person-to-

person infection or some other mechanism such as imitation of one's peers. However, the debate is clouded by the use of structural equivalence as the definition of position. One problem with this choice is the assumption that structural equivalence is conceptually and empirically different from cohesion. It is not. As we have discussed earlier, sets of structurally equivalent actors form a kind of cohesive subset known as a 2-clique. Hence, if we take a structural equivalence approach to defining position, we cannot logically test whether position is a better predictor than cohesive subset membership. At best, we can choose between two kinds of cohesive subsets.<sup>11</sup>

Another problem concerns the linkage between the choice of network models (cohesion versus structural equivalence) and the choice of theoretical explanatory mechanisms (direct infection versus imitation or other mechanisms). At first glance it might appear that we could statistically partial out the cohesive component of structural equivalence. Friedkin (1984) attempted exactly this. Noting that direct connections among structurally equivalent actors confound the comparison with cohesive subsets, Friedkin partialled out these effects and found that structural equivalence loses a great deal of its predictive power. However, as Friedkin noted, removing the effects of direct connections is not nearly enough, since structurally equivalent actors will still share all of their contacts. If any or all of these contacts are infected, we would still expect structurally equivalent actors to be homogeneous. Consequently, both cohesive/relational and structural equivalence approaches are consistent with the mechanism of infection/transmission, and choosing one over the other does not necessitate a different explanatory mechanism.<sup>12</sup>

Friedkin also attempted to control for the number of shared contacts or two-step paths connecting equivalent actors. However, it is

<sup>11</sup>See Borgatti, Everett, and Shirey (1990) for a discussion of the different definitions of cohesive subsets.

<sup>12</sup>On the other hand, relational and structural equivalence approaches do not necessarily imply the same causal mechanisms. This point was made convincingly by Burt (1987, p. 1293*n*), who realized that "a vulgar understanding of structural equivalence views [diffusion] by structural equivalence to be no more than an indirect effect of cohesion." He dismissed this view on empirical grounds because, unlike Friedkin (1984), Burt found no evidence in the *Medical Innovation* data for diffusion via direct connections. He therefore concluded that the ability of structural equivalence to predict homogeneity could not be due to an infection-type mechanism.

impossible to control for all two-step paths because no actors (except isolates) can be structurally equivalent and yet share no contacts! Ultimately, the notion of structural equivalence without proximity is meaningless: It is an inseparable part of the concept.<sup>13</sup> Therefore, if we are truly interested in noncohesive (or, substantively, noninfectious) determinants of social homogeneity, we cannot use structural equivalence. Instead, we should use structural isomorphism, which measures structural similarity unconfounded by proximity.

Unlike structural equivalence, isomorphism entails a different theoretical explanation for diffusion than that posited by the relational or cohesion-based approach. In particular, the mechanism cannot depend upon interpersonal transmission of any kind, since isomorphic actors need not be connected even indirectly. An example is a centrality-based explanation, on the hunch that physicians who are peripheral to the medical community might be more likely to adopt than physicians who are more central. Adopting the latest medical advances might be a way for marginal physicians to gain prestige and attention and thereby move toward the center. Similarly, central physicians might be slow to adopt innovations that could make unwelcome changes to the status quo. Another mechanism might be the similar responses we expect from similarly constructed organisms to similar environments. For example, if certain respondents achieve similar scores in a psychometric test that measures, let's say, authoritarianism, it might be because they have the same combinations of relationships with their respective parents, bosses, and spouses, yielding similar experiences and opportunities and ultimately similar personality characteristics.

In reality, non-transmission-based mechanisms of the sort illustrated above might not exist, or if they do exist, their effects might be negligible compared with the powerful forces of person-to-person transmission. If so, cohesive subsets of actors will evince greater homogeneity than sets of isomorphic actors, and we shall be able to conclude that the relational approach predicts better than a posi-

<sup>13</sup>However, this is not to say that there aren't kinds of cohesive subgroups that are more cohesive than structural equivalence. Sets of structurally equivalent actors are 2-cliques, which were introduced by Luce (1950) with the express purpose of relaxing the extreme cohesiveness required by the clique concept (Luce and Perry 1949). Since that time, other cohesive subset definitions have appeared, which are intermediate in cohesiveness between true cliques and  $n$ -cliques (Alba 1973; Mokken 1979; Seidman and Foster 1978).

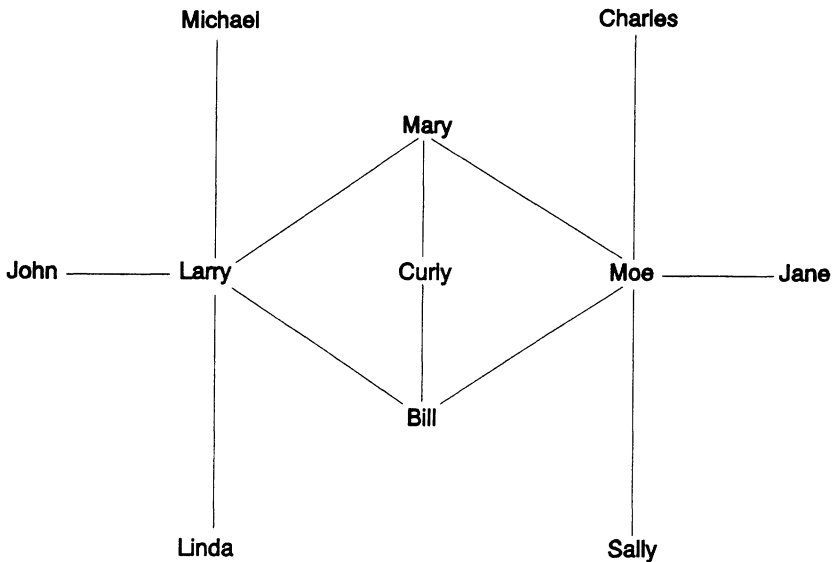

FIGURE 13. Mary and Bill are structurally equivalent.

tional approach. If both structural similarity and cohesion are important determinants of diffusion, then structural equivalence could well emerge as the more powerful predictor.

From the point of view of building structural theory in general, however, we must be careful when using structural equivalence as an independent variable. Because it necessarily confounds structural similarity with proximity, it is conceptually inelegant. Moreover, it prevents evaluation of the relative contributions of structural similarity and cohesion to predicting the outcome variable. A cleaner and more useful alternative is to use both cohesion and structural isomorphism as theoretically orthogonal independent variables, thereby separating the components of structural equivalence while not losing the benefits of either.

There is another advantage of structural isomorphism over structural equivalence in building structural theory. Suppose we expect actors occupying the same position to have similar outcomes with respect to a particular variable of interest. For example, we are interested in testing the hypothesis that position in the social-support network at a nursing home predicts the number of visits required by a

doctor. Suppose we operationalize position as structural equivalence, check the correspondence between position and outcome, and find that the hypothesis is supported. For example, suppose it turns out that Bill and Mary in Figure 13 both require a great deal of medical attention. The critical question from the point of view of structural theory is whether the similar result is due to some structural feature of their position (such as being the only bridges between two sets of actors) or to their being connected to the same three maddening individuals, named Moe, Curly, and Larry, and only these three. With structural equivalence, we cannot distinguish between these two possibilities because every member of a set of structurally equivalent actors is connected to the same unique combination of individuals. In this sense, structural equivalence is highly particularistic and individualistic and not, in this sense, structural. Isomorphism, in contrast, is purely structural. The effects of structural similarity are never confounded with the effects of specific individuals. For example, if in Figure 13 the isomorphic actors Michael, John, Linda, Charles, Jane, and Sally all have the same medical outcomes, then we can reasonably infer that it is due to some structural attribute of their common position, such as being peripheral.

## 6. SUMMARY

We have attempted to detail the differences between structural equivalence and more-abstract equivalences, focusing on the abstract equivalence most comparable to structural equivalence, which is structural isomorphism. Whereas structural equivalence defines position in terms of who an actor knows, structural isomorphism defines it in terms of the way an actor is connected. Whereas structurally equivalent actors are both proximate and similar, structurally isomorphic actors are only similar. Among methodologists, these distinctions have long been understood. However, the implications for building sociological theory have not previously been drawn out. For example, we have pointed out that while cohesive/relational and structural equivalence approaches to social homogeneity do not demand that different causal mechanisms be posited, cohesion and structural isomorphism almost always do. We have also pointed out, echoing Sailer (1978), that structural equivalence should not be used to model role systems, despite numerous studies that do just that.



## REFERENCES

- Alba, R. D. 1973. "A Graph-Theoretic Definition of a Sociometric Clique." *Journal of Mathematical Sociology* 3:133-26.
- Anderson, J. G., and S. J. Jay. 1985. "The Diffusion of Medical Terminology: Social Network Analysis and Policy Research." *Sociological Quarterly* 26: 49-64.
- Borgatti, S. P. 1987. *User's Manual for AL: Analytic Language*. Irvine: University of California, School of Social Sciences.
- Borgatti, S. P., J. P. Boyd, and M. G. Everett. 1989. "Iterated Roles: Mathematics and Application." *Social Networks* 11:159-72.
- Borgatti, S. P., and M. G. Everett. 1989. "The Class of All Regular Equivalences: Algebraic Structure and Computation." *Social Networks* 11:65-88.
- Borgatti, S. P., M. G. Everett, and P. R. Shirey. 1990. "LS Sets, Lambda Sets and Other Cohesive Subsets." *Social Networks* 12:337-57.
- Breiger, R. L. 1981. "Structures of Economic Interdependence Among Nations." Pp. 353-80 in *Continuities in Structural Inquiry*, edited by P. M. Blau and R. Merton. New York: Free Press.
- Breiger, R. L., S. Boorman, and P. Arabie. 1975. "An Algorithm for Clustering Relational Data with Applications to Social Network Analysis." *Journal of Mathematical Psychology* 12:329-83.
- Breiger, R. L., and P. E. Pattison. 1986. "Cumulated Social Roles: The Duality of Persons and their Algebras." *Social Networks* 8:215-56.
- Brym, R. J. 1988. "Structural Location and Ideological Divergence: Jewish Marxist Intellectuals in Turn-of-the-Century Russia." Pp. 359-79 in *Social Structures*, edited by B. Wellman and S. D. Berkowitz. Cambridge: Cambridge University Press.
- Burt, R. S. 1976. "Positions in Networks." *Social Forces* 55:93-122.
- . 1978. "Cohesion Versus Structural Equivalence as a Basis for Network Subgroups." *Sociological Methods and Research* 7:189-212.
- . 1979. "A Structural Theory of Interlocking Corporate Directorates." *Social Networks* 1:415-35.
- . 1982. *Toward a Structural Theory of Action*. New York: Academic Press.
- . 1987. "Social Contagion and Innovation: Cohesion Versus Structural Equivalence." *American Journal of Sociology* 92:1287-1335.
- . 1989. STRUCTURE Version 4.0. New York: Columbia University, Research Program in Structural Analysis.
- Burt, R. S., and P. Doreian. 1982. "Testing a Structural Model of Perception: Conformity and Deviance with Respect to Journal Norms in Elite Sociological Methodology." *Quality and Quantity* 16:109-50.
- Caldeira, G. A. 1988. "Legal Precedent: Structures of Communication Between State Supreme Courts." *Social Networks* 10:29-55.
- Coleman, J., E. Katz, and H. Menzel. 1957. "The Diffusion of an Innovation Among Physicians." *Sociometry* 20:253-70.
- Cook, K. S., and R. M. Emerson. 1978. "Power, Equity and Commitment in Exchange Networks." *American Sociological Review* 43:721-39.

- Cook, K. S., R. M. Emerson, M. R. Gillmore, and T. Yamagishi. 1983. "The Distribution of Power in Exchange Networks: Theory and Experimental Results." *American Journal of Sociology* 89:275–305.
- DiMaggio, P. 1986. "Structural Analysis of Organizational Fields: A Block-model Approach." *Research in Organizational Behavior* 8:335–70.
- Emerson, R. M. 1962. "Power-Dependence Relations." *American Sociological Review* 27:31–40.
- Erickson, B. H. 1988. "The Relational Basis of Attitudes." Pp. 99–122 in *Social Structures*, edited by B. Wellman and S. D. Berkowitz. Cambridge: Cambridge University Press.
- Evan, W. M. 1966. "The Organization-Set: Toward a Theory of Interorganizational Relations." Pp. 173–91 in *Approaches to Organizational Design*, edited by J. D. Thompson. New York: McGraw Hill.
- Everett, M. G. 1985. "Role Similarity and Complexity in Social Networks." *Social Networks* 7:353–59.
- Everett, M. G., and S. P. Borgatti. 1988. "Calculating Role Similarities: An Algorithm that Helps Determine the Orbits of a Graph." *Social Networks* 10:77–92.
- . 1990. "Any Colour You Like It." *Connections* 13:19–22.
- Everett, M. G., J. P. Boyd, and S. P. Borgatti. 1990. "Ego-Centered and Local Roles: A Graph-Theoretic Approach." *Journal of Mathematical Sociology* 15:163–72.
- Faust, K. 1988. "Comparison of Methods for Positional Analysis: Structural and General Equivalences." *Social Networks* 10:313–41.
- Freeman, L. C. 1978. "Centrality in Social Networks: Conceptual Clarification." *Social Networks* 1:215–39.
- Friedkin, N. E. 1984. "Structural Cohesion and Equivalence Explanations of Social Homogeneity." *Sociological Methods and Research* 12:235–61.
- Galaskiewicz, J., and K. R. Krohn. 1984. "Positions, Roles, and Dependencies in a Community Integration System." *Sociological Quarterly* 25:527–50.
- Harary, F. 1969. *Graph Theory*. Reading, MA: Addison-Wesley.
- Hartman, R. L., and J. D. Johnson. 1990. "Social Contagion and Multiplexity: Communication Networks as Predictors of Commitment and Role Ambiguity." *Human Communication Research* 15:523–48.
- Hofstadter, D. R. 1985. *Metamagical Themas: Questing for the Essence of Mind and Pattern*. New York: Basic Books.
- Hummell, H., and W. Sodeur. 1987. "Strukturbeschreibung von Positionen in sozialen Beziehungsnetzen." Pp. 1–21 in *Methoden der Netzwerkanalyse*, edited by F. U. Pappi. Munich: Oldenbourg.
- Kadushin, C. 1982. "Social Density and Mental Health." Pp. 147–58 in *Social Structure and Network Analysis*, edited by P. V. Marsden and N. Lin. Beverly Hills: Sage Publications.
- Knocke, D., and R. S. Burt. 1983. "Prominence." Pp. 195–222 in *Applied Network Analysis*, edited by R. S. Burt and M. J. Minor. Newbury Park, CA: Sage Publications.
- Krackhardt, D., and L. W. Porter. 1986. "The Snowball Effect: Turnover

- Embedded in Communication Networks." *Journal of Applied Psychology* 71:50–55.
- Krippendorff, K. 1971. "Communication and the Genesis of Structure." *General Systems* 16:171–85.
- Leavitt, H. J. 1951. "Some Effects of Certain Communication Patterns on Group Performance." *Journal of Abnormal and Social Psychology* 46:38–50.
- Linton, Ralph. 1936. *The Study of Man*. New York: Appleton-Century.
- Lorrain, F. P., and H. C. White. 1971. "Structural Equivalence of Individuals in Networks." *Journal of Mathematical Sociology* 1:49–80.
- Luce, R. D. 1950. "Connectivity and Generalized Cliques in Sociometric Group Structure." *Psychometrika* 15:169–90.
- Luce, R. D., and A. D. Perry. 1949. "A Method of Matrix Analysis of Group Structure." *Psychometrika* 14:95–116.
- Markovsky, B., D. Willer, and T. Patton. 1988. "Power Relations in Exchange Networks." *American Sociological Review* 53:220–36.
- Merton, R. K. 1959. *Social Theory and Social Structure*. Glencoe, IL: Free Press.
- Mokken, R. J. 1979. "Cliques, Clubs and Clans." *Quality and Quantity* 13:161–73.
- Nadel, S. F. 1957. *The Theory of Social Structure*. London: Cohen and West.
- Nemeth, R., and D. Smith. 1985. "International Trade and World-System Structure: A Multiple Network Analysis." *Review* 8:517–60.
- Pattison, P. E. 1988. "Network Models: Some Comments on Papers in this Special Issue." *Social Networks* 10:383–411.
- Pitts, F. R. 1978. "The Medieval River Trade Network of Russia Revisited." *Social Networks* 1:285–92.
- Rogers, E. M. 1979. "Network Analysis of the Diffusion of Innovations." Pp. 137–64 in *Perspectives in Social Network Research*, edited by P. W. Holland and S. Leinhardt. New York: Academic Press.
- Sailer, L. D. 1978. "Structural Equivalence: Meaning and Definition, Computation and Application." *Social Networks* 1:73–90.
- Seidman, S. B., and B. L. Foster 1978. "A Graph-Theoretic Generalization of the Clique Concept." *Journal of Mathematical Sociology* 6:139–54.
- Smith, D. A., and D. R. White. 1986. "Dynamic Analysis of International Trade and World-System Structure 1965–1980." Paper presented at the *Sunbelt International Network Conference*, San Diego.
- Snyder, D., and E. L. Kick. 1979. "Structural Position in the World System and Economic Growth, 1955–1970: A Multiple-Network Analysis of Transnational Interactions." *American Journal of Sociology* 84:1096–1126.
- Wallerstein, Immanuel. 1974. *The Modern World System*. New York: Academic Press.
- Wellman, B. 1988. "Structural Analysis: From Method and Metaphor to Theory and Substance." Pp. 19–61 in *Social Structures*, edited by B. Wellman and S. D. Berkowitz. Cambridge: Cambridge University Press.
- White, D. R. 1984. "REGGE: A Regular Graph Equivalence Algorithm for

- Computing Role Distances Prior to Blockmodeling." Unpublished manuscript, University of California, Irvine.
- White, D. R., and K. P. Reitz. 1983. "Graph and Semigroup Homomorphisms on Networks of Relations." *Social Networks* 5:193–235.
- White, H. C. 1988. "Varieties of Markets." Pp. 226–60 in *Social Structures*, edited by B. Wellman and S. D. Berkowitz. Cambridge: Cambridge University Press.
- White, H. C., S. A. Boorman, and R. L. Breiger. 1976. "Social Structure from Multiple Networks: I. Blockmodels of Roles and Positions." *American Journal of Sociology* 81: 730–80.
- Winship, Christopher. 1988. "Thoughts about Roles and Relations: An Old Document Revisited." *Social Networks* 10:209–31.
- Winship, Christopher, and M.J. Mandel. 1983. "Roles and Positions: A Critique and Extension of the Blockmodeling Approach." Pp. 314–44 in *Sociological Methodology 1983–84*, edited by S. Leinhardt. San Francisco: Jossey-Bass.